

ENVR 754 Air Pollution Control Laboratory on Cyclone Performance

Objectives

The purposes of this laboratory are:

- (a) to measure the fractional efficiency curve for a cyclone,
- (b) to determine how the efficiency curve changes with changes in air flow through the cyclone, and
- (c) to compare the results of these measurements with theory and with standards.

Procedure

We will use the Aerodynamic Particle Sizer (APS) model 3321 to measure the efficiency of a cyclone used for sampling. A schematic drawing of the setup is shown below.

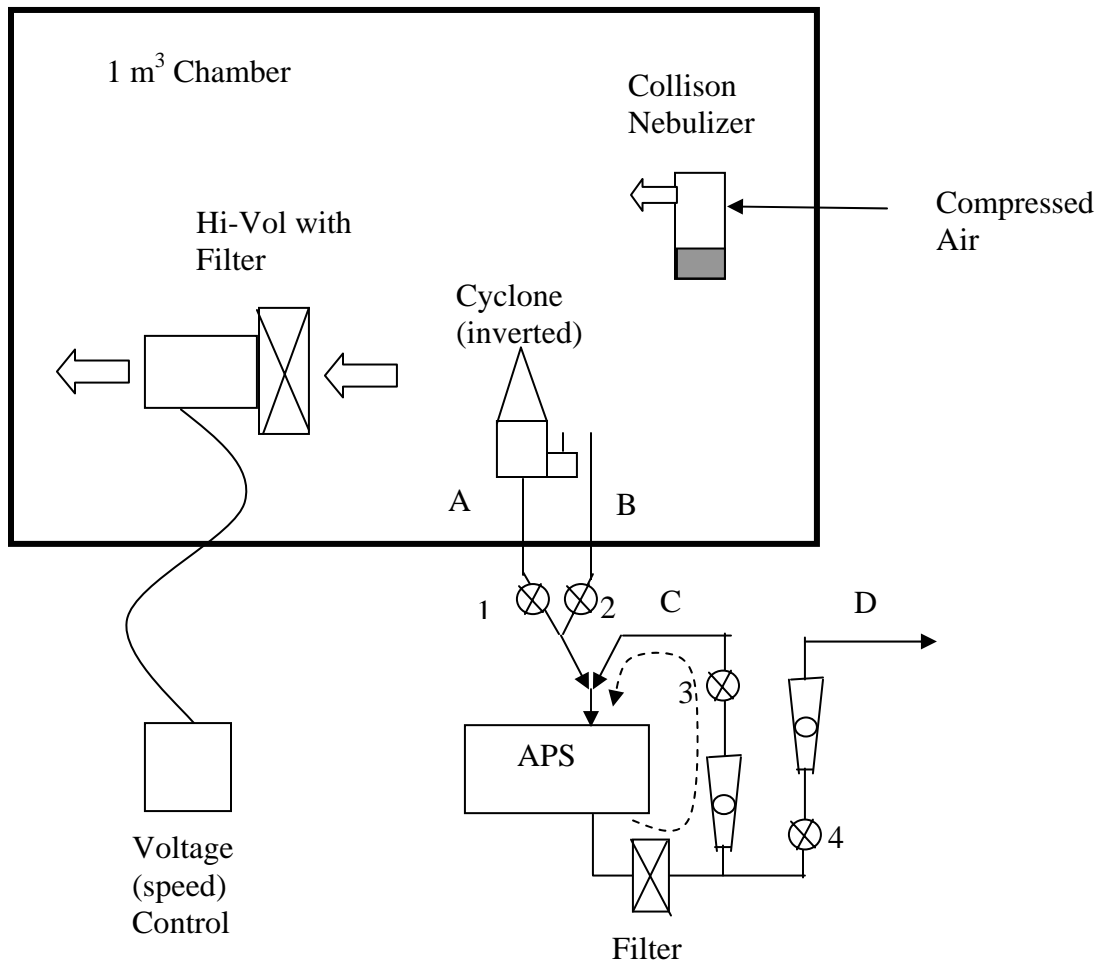

Rationale – Note that the APS has an internal pump and mass flow controllers that will maintain flow through the APS at 5.0 Lpm under all conditions. We wish to sample through the cyclone, Line A, or the bypass, Line B, at flows that range from 1.6 to 4.2 Lpm. To accomplish this, we can recirculate part of the flow through the APS so that its 5 Lpm flow will be maintained.

The difference between the recirculated flow and the 5 Lpm flow will be the flow through either the cyclone or the bypass, Lines A or B. The flow through the cyclone or bypass will exit through Line D, where its value can be read using the rotameter on that line. The sum of the flows from the rotameters on Line C for recirculation, and Line D for the cyclone, should always total 5 Lpm.

Follow the steps below to manage the system.

1. Generate an oil mist aerosol using the Collison nebulizer. Pressure to the nebulizer should be about 6 psig.
2. The Hi-Vol has a filter that will remove aerosol and allow control of the concentration. Adjust the voltage to the Hi-Vol until the concentration measured by the APS, when sampling through line B, is about 500 particles/cm³.
3. Valves marked “1” and “2” are pinch clamps. If clamp “1” is on, then sample is drawn through line B, whereas if clamp “2” is on, sample is drawn through the cyclone and line A.
4. Valves marked “3” and “4” are used to regulate flows. Note that line C recirculates flow from the outlet of the APS back to the inlet of the APS, and is necessary to maintain the total flow to the APS at 5 Lpm.
5. Line D carries the sample flow from the chamber, through the APS, and out. Flow through Line A or Line B is controlled through valve “4” and read using the rotameter in line D.
6. To increase flow through Line A or B, close valve “3” and open valve “4” to reduce recirculation flow through line C and increase outlet flow through line D.
7. To decrease flow through Line A or B, open valve “3” and close valve “4” to increase recirculation flow through line C and decrease outlet flow through line D.

To conduct an experiment, first establish the desired flows through the recirculation and sampling lines using the rotameters on Lines C and D. Then move the pinch clamp back and forth between lines A and B to sample through the bypass or the cyclone. Measure the concentration and size distribution of the aerosol that goes through the bypass or the cyclone using the APS. A one-minute sample is sufficient. Make five measurements as follows:

- (1) cyclone, (2) bypass, (3) cyclone, (4) bypass, (5) cyclone (1)

Then change the desired flows and repeat the APS measurements at the new flow condition.

Conduct tests at cyclone flows of 1.6 Lpm and 4.2 Lpm. At 1.6 Lpm this cyclone is supposed to have fractional efficiency characteristics that correspond to criteria for “thoracic” sampling, whereas at 4.2 Lpm the cyclone is supposed to sample according to “respirable” criteria.

Data Processing

Download all data from the APS into an Excel file. For data at each flow, calculate cyclone penetration as a function of particle size by taking the ratio of particle counts through the cyclone divided by counts through the bypass.

$$Pt(d) = \frac{N(d)_{\text{cyclone}}}{N(d)_{\text{bypass}}} \quad (2)$$

where $Pt(d)$ is penetration for particles of size “d”, $N(d)_{\text{cyclone}}$ is the number of particles of that size counted in one minute through the cyclone sampling line, and $N(d)_{\text{bypass}}$ is the number of particles of that size counted in one minute through the bypass line.

By making five measurements in the order given by line (1) above, you will be able to determine four values for penetration for particles of each size, one for each pair of measurements. That is, your first penetration measurement will come from (1)/(2), the second from (3)/(2), then (3)/(4) and (5)/(4). From these measurements, determine the average penetration and the standard deviation, for particles of each size.

Repeat these measurements for both flows through the cyclone. Note that the rotameters in this lab utilize units of ft^3/hr . For your reference, 1.6 Lpm = $3.4 \text{ ft}^3/\text{hr}$ and 4.2 Lpm = $8.9 \text{ ft}^3/\text{hr}$.

Report

Outline briefly what you did. Plot efficiency versus particle diameter for the cyclone at both air flows. Use a separate figure for each air flow.

Calculate the expected efficiency for the cyclone according to theory we discuss in class. Plot theoretical efficiency on the same two figures.

Finally, use the Hinds book to find the relationship between efficiency and particle diameter for thoracic sampling and for respirable mass sampling. Plot these standards for thoracic and respirable mass sampling on the same two figures.

Your report must not exceed three pages. The first page should contain only your name, the date, and a brief paragraph that summarizes your work and findings. The second and third pages should present your results, including all figures. You may attach appendices if necessary to present your data or details of your calculations.